

NOTE: DIAGONAL MOUNTING TUBES ALTERNATE WITH TRACK JOINS. TREAD CONSTRUCTION AND MATERIAL MAY VARY.

**MOUNTING TO STUDS USING DIAGONAL MOUNTING TUBES**

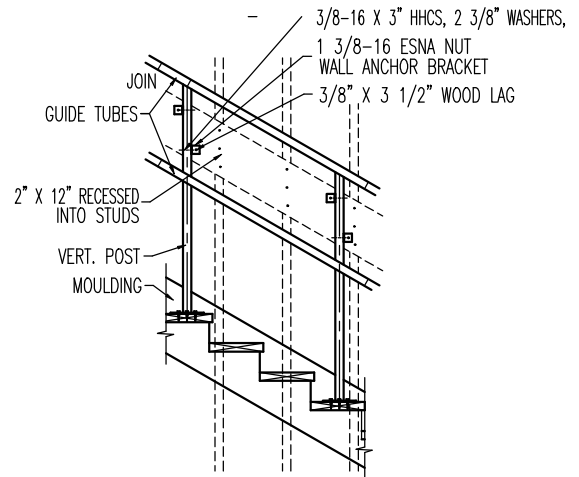

**MOUNTING TO RECESSED 2\"/>**

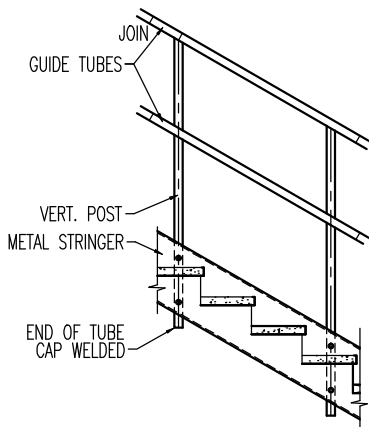

**MOUNTING TO SIDE OF STEEL STRINGER**

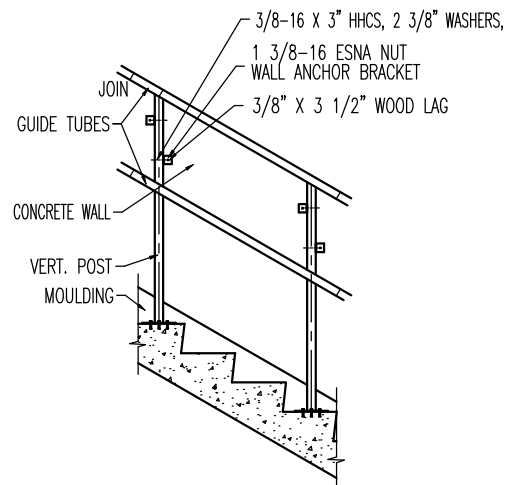

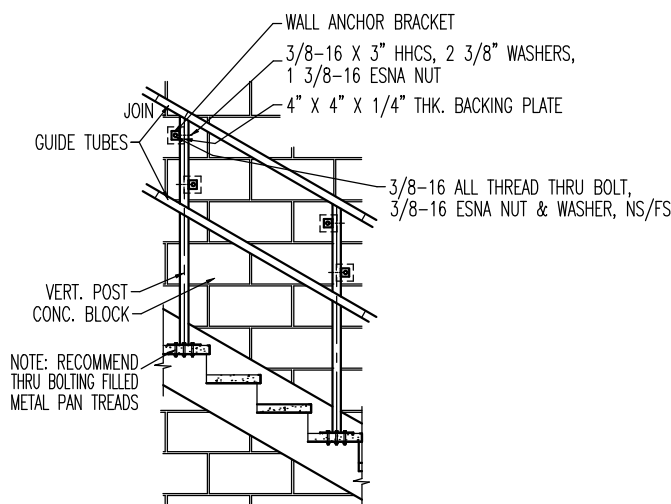

**MOUNTING TO CONCRETE WALL WITH MOULDING OR STRINGER PROTRUSION**

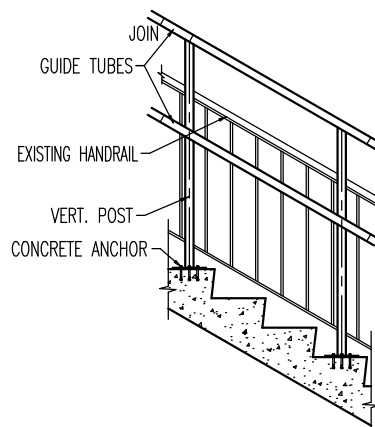

**MOUNTING TO CONCRETE BLOCK WALL USING WALL ANCHOR BRACKETS**



**FREE STANDING TRACK MOUNTED DIRECTLY TO TREADS**

 <p>4001 East 138th Street Grandview, MO 64030-2837</p>	MODEL:	IL-2000 AND IL-92	
	DEALER:		
 <p>Inclined Platform Lifts</p>	CUSTOMER:		
	JOB or P.O.#:		
SCALE:	DATE:	ORDER NUMBER:	
NTS	02/19/99	CL-TYP-WALL	