

# mjnivator<sup>®</sup>

RESIDENTIAL ELEVATOR  
with Knock-Down Cab

## Unit Dimensional Drawing

### SPECIFICATIONS

- Travel: 16 feet maximum
- Capacity: 450 lb. maximum
- Speed: 20 feet per minute
- Track Wt.: 2 1/4 lbs per foot
- Car Wt.: 290 lbs
- Header Wt.: 225 lbs
- Windows: 1/4" clear acrylic
- Minimum Floor Space & second floor rough opening  
Req: 35 3/4" x 54"
- Electrical Req.:
  - Dedicated 115V - 20 AMP
  - Std. modular phone jack

### DRIVE SYSTEM

- 3/4 HP open drip-proof motor with brake & manual lowering access port. Motor is 120 V, 10.5 A, 1140 RPM, 1 Phase, 60 Cycle, Reversing
- 80:1 helical-worm unit with double 1 1/4" diameter output shafts
- Suspended by two 1/4" diameter, 7x19 strand 7000 lb. breaking strength aircraft cables

### SAFETY FEATURES

- Manual lowering device
- Electro mechanical interlock car door
- Grab handles on car door
- Emergency stop button in car with audible alarm
- Slack cable safety device
- Upper landing hatch cover with safety sensors
- Upper and lower limit switches
- Upper and lower final limit switch
- Open door sensor
- Constant pressure switches
- Platform safety sensor
- 24 VAC control system

Right Hand cab shown. Information is subject to change without notice.  
Dimensions are nominal.

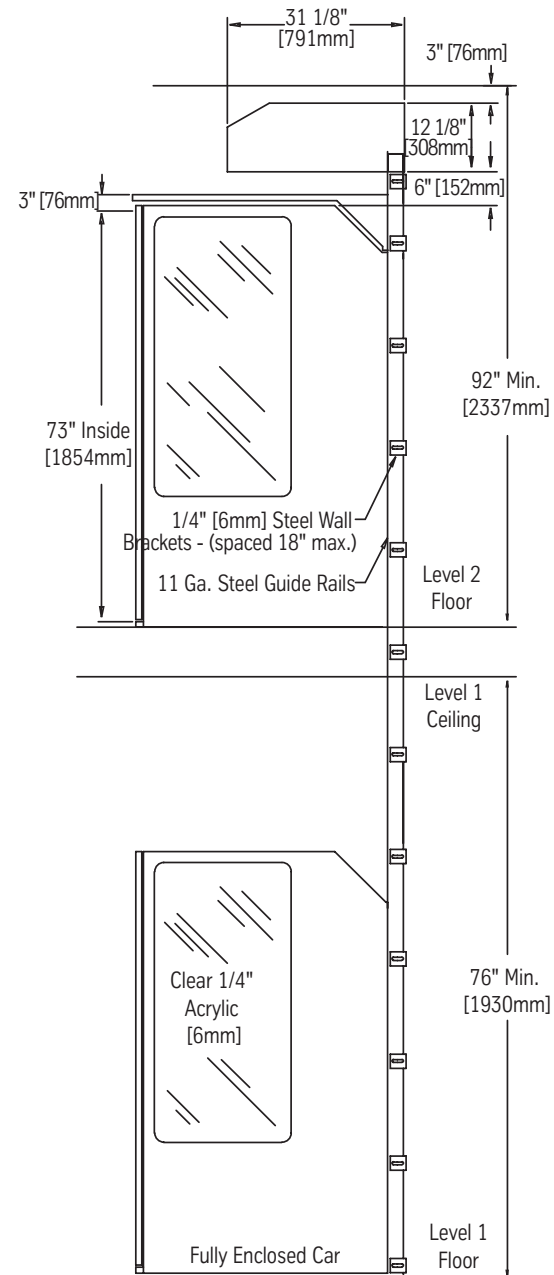
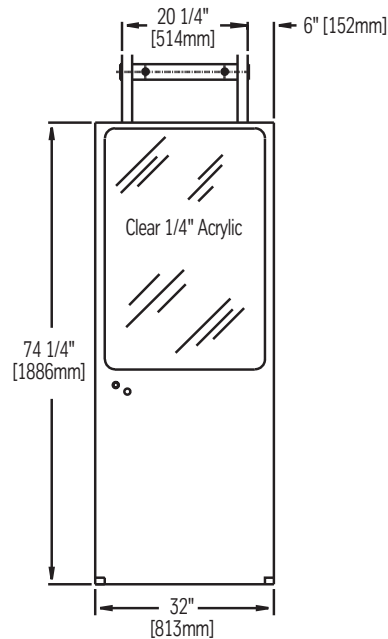
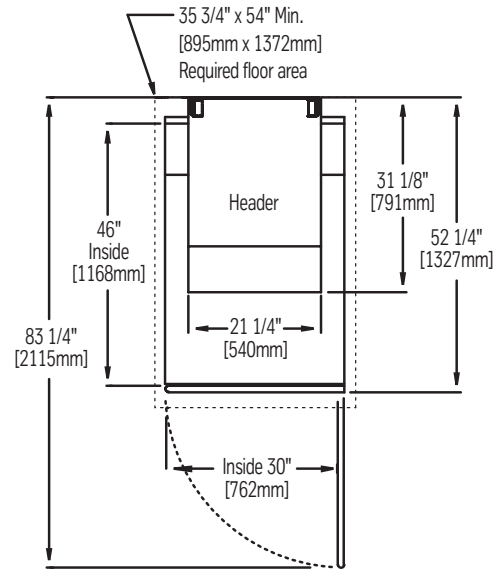

**ThyssenKrupp Access**  
Residential Elevator Division



ThyssenKrupp