

# RA<sup>®</sup> 750

## PORCH-LIFT

VERTICAL PLATFORM LIFT

### Unit Dimensional Drawing

#### STANDARD EQUIPMENT

Platform Control Switch with Emergency Stop, Key Operation  
 All Controls – constant pressure  
 Low Voltage Controls – 24 Volt  
 Platform Safety Pan  
 36" high Platform Guard Panels  
 36" x 48" Platform with Non-skid Surface  
 15 1/2" long Automatic Folding Access Ramp  
 750 lb. Capacity  
 Ivory White Powder Coat Finish  
 UL Listed when appropriately equipped  
 3/4 HP Motor, 120 V, 60 Hz  
 Acme Screw Drive  
 V-Belt Drive System with Monitoring Device  
 ASME/ANSI A18.1 (formerly A17.1: Part XX, Section 2100 for private residences) when appropriately equipped with Options.

#### OPTIONAL EQUIPMENT

36"x54" platform  
 42" high Top Landing Gate  
 Access ESI (doors & gates by others)  
 Flush Mount Electric Strike (door/gate by others)  
 Keyed Dead Latch (for use w/Flush Mount Electric Strike)  
 Fascia Panel, 36" wide  
 Manual Lowering Device  
 Hand Rail  
 Wireless Remote

4001 East 138th Street  
 Grandview, MO 64030-2837  
 Phone: 816-763-3100  
 Fax: 816-763-4467  
 Toll Free: 800-925-3100  
 www.tkaccess.com

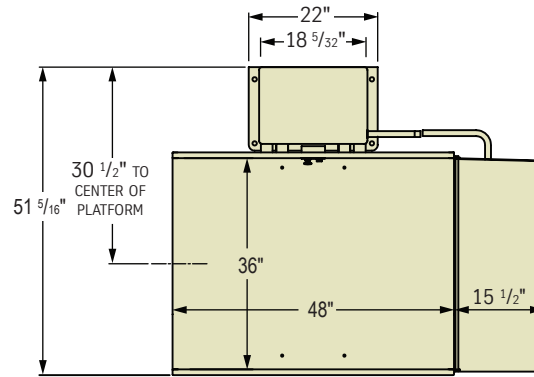

PLAN VIEW

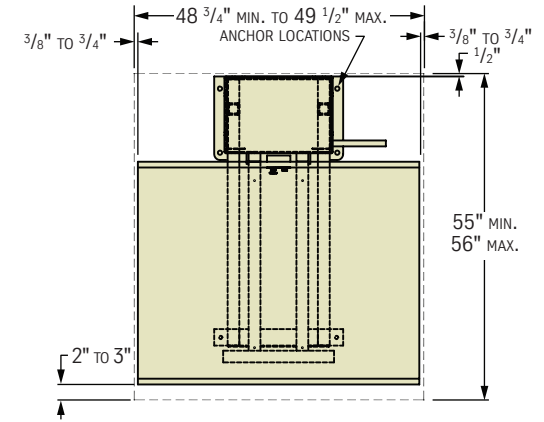

FLOOR & SHAFTWAY LAYOUT

Model PL-RA750			
Model	Max. Lifting Ht.	Min. Lifting Ht.	Tower Height
24	25"	0"	47 1/4"
36	37"	24" 14" *	59 1/4"
50	51"	36" 26" *	73 1/4"
72	73"	60" 50" *	113 5/8"

\*With extender kit.

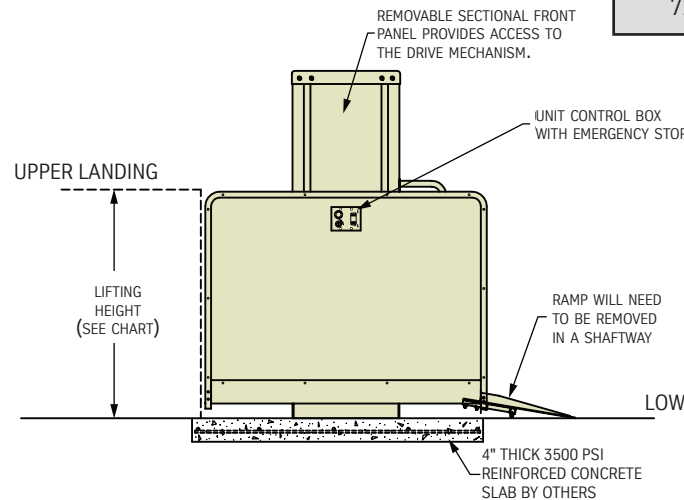

FRONT ELEVATION

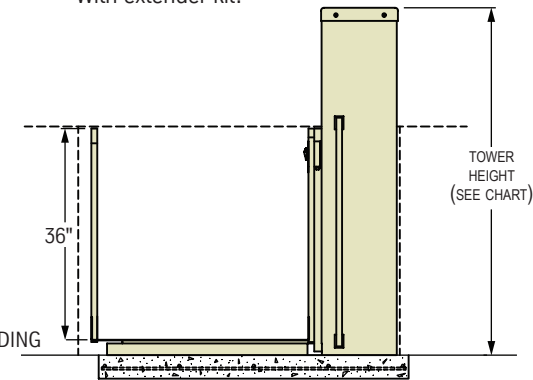

LOWER LANDING SIDE ELEVATION

**ThyssenKrupp Access**  
 Accessibility Division



ThyssenKrupp