

Excel®

Straight stair lift w/folding track



ThyssenKrupp Access
Accessibility Division



ThyssenKrupp

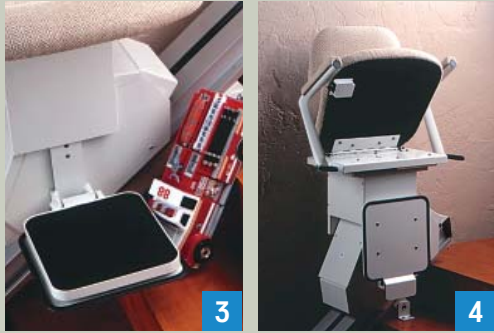

1. Excel A/C stair lift. Plugs into standard household current.
2. Swivel seat: Lever release allows seat to swivel and lock at 60° and 90° at top level, thus allowing rider to safely exit.
3. Obstruction sensor: Lift detects something in its path and automatically stops so you can remove it.
4. Compact design: Seat, arms and footrest fold up when unit is not in use.
- 5a., 5b. Manual folding track at lower landing
6. Controls: Constant pressure control on seat and wireless remotes.

Excel features

- **Control System:** A/C powered with SoftStart/SoftStop. Motor: 1/2 hp, 120 VDC, 60 Hz (reversible)
- **Rated load:** 300 pounds (135 kg)
- **Speed:** 18-25 fpm (.09 - .13 ms)
- **Incline limits:** 25° to 45°
- **Travel:** 32' max. (9.75 m)
- **Power supply:** 115 VAC, 60 Hz, 3-wire grounded outlet
- **Controls:** Constant pressure control on seat and wireless remote controls
- **Drive system:** Rack and pinion
- **Brake:** Self-locking worm gear
- **Track:** 6 1/2" (165 mm) extruded aluminum; manual folding at lower landing
- **Track length:** 16' stock or custom cut
- **Track finish:** Clear anodized
- **Unit finish:** Ivory white powder coat finish
- **Seat:** 19" (483 mm) wide seat with two straight fold-up arms, and 60°/90° locking swivel seat at top landing
- **Upholstery:** Taupe or misty gray vinyl; oatmeal herringbone fabric
- **Safety devices:** Carriage obstruction sensors, footrest obstruction sensors, swivel seat cut-off switch, final limit switches, and seat belt

- **Listing:** ETL, cETL and CSA Listed
- **Warranty:** Five years on drive train and two years on all component parts

Optional Equipment

- Key switch unit controls
- Joystick control
- Hand-held pendant control
- Controls in ends of arms
- Overspeed brake
- White track as shown on cover

Upholstery options:



Taupe vinyl (upper left),
Misty gray vinyl (upper right),
Oatmeal herringbone fabric (left)

Specifications and/or colors subject to change without notice.

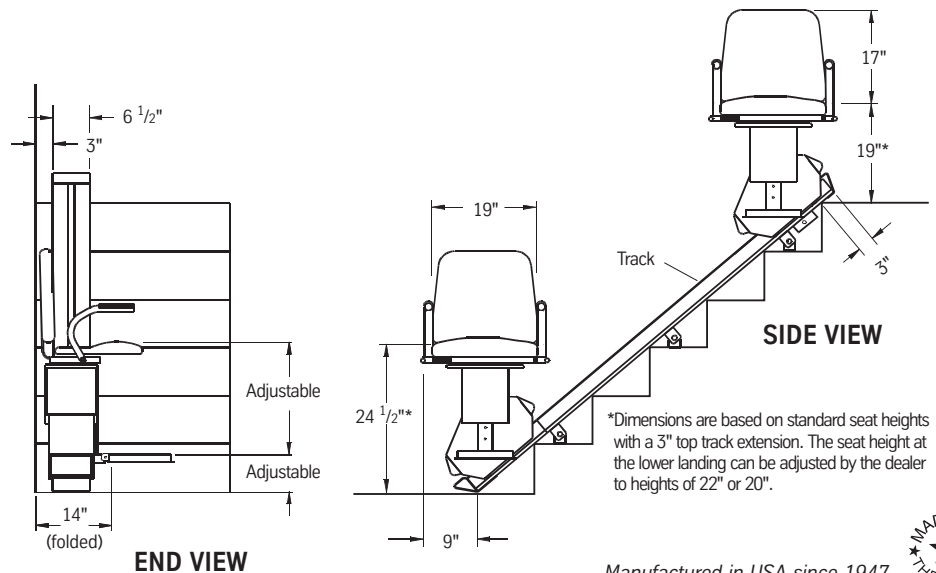

Manufactured in USA since 1947.



ThyssenKrupp Access Corp.
4001 East 138th Street
Grandview, MO 64030

800.829.9760
www.tkaccess.com