

Citia™ Excel A/C or BOS Stair Lift

Unit Dimensional Drawing

SPECIFICATIONS

Rated Load: 300 pounds (135kg)
Speed: 19 fpm (.10 ms)
Travel: 32' max. (9.75 m) (track length)
Power Supply: 115 VAC, 60 Hz, 3-wire grounded outlet
Incline Limits: 25° to 45° (and up to 55° with local jurisdiction approval)
 ETL and cETL Listed

STANDARD EQUIPMENT

Drive System: Rack and pinion
Motor: 1/2 hp, 24 VDC (reversible)
Control System:

Option 1) A/C with SoftStart/SoftStop control board with diagnostic LED's

Option 2) Battery Operated System (BOS) with SoftStart/SoftStop control board with diagnostic LED's with two 12-volt maintenance free batteries. Integrated charge stations at top and bottom, charge fault alarm, low battery indication through audible alarm, reduced speed and LED indication, energy saving sleep mode when not in use

Controls: Constant pressure handheld pendant control (with pendant holster) and 2 wire-less remote controls (infra-red).

Charging Stations: Integrated charge stations at top and bottom, charge fault alarm, low battery indication through audible alarm, reduced speed and LED indication

Brake: Self-locking worm gear

Track: 5 1/2" wide extruded aluminum

Track Length: 16' stock or custom cut

Track Finish: Unfinished aluminum

Unit Finish: Ivory white powder coat finish

Upholstery: Oatmeal herringbone fabric; taupe or misty gray vinyl over padded seat and seat back

Seat: 18" (457mm) wide seat with two independently folding arms, folding seat, seat belt, and 70° locking swivel seat at top and bottom landing

Safety Devices:

Footrest obstruction sensors
 Swivel seat cut-off switch
 Final limit switches
 Seat belt

Warranty: Five years on drive train and two years on all component parts

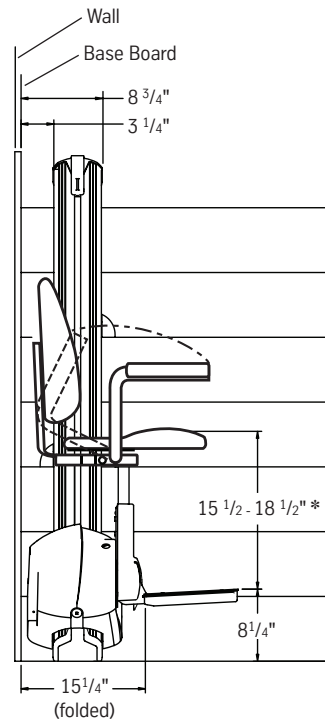

END VIEW

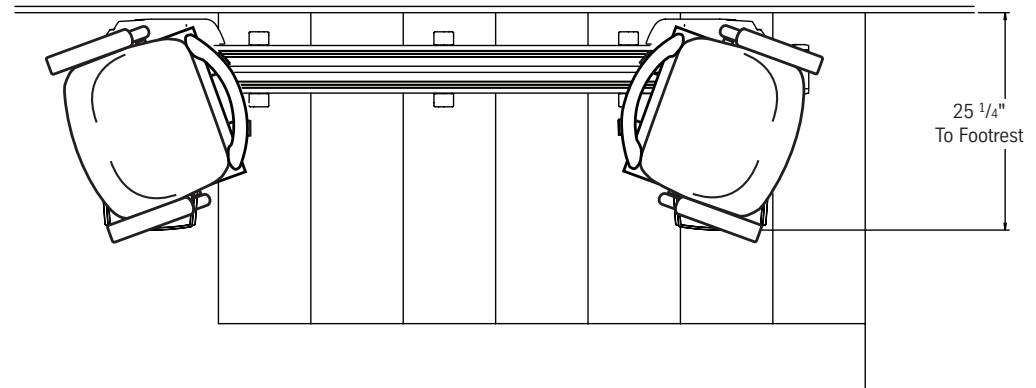

TOP VIEW

*Dimensions are based on a 35° stair angle and standard seat heights with a 2 3/8" top track extension. The seat height at the lower landing can be adjusted by the dealer to heights between 23 3/4" - 26 3/4". See Measurement Sheet - Order Form for details on calculating the track extension based on desired seat heights at the top and lower landings.

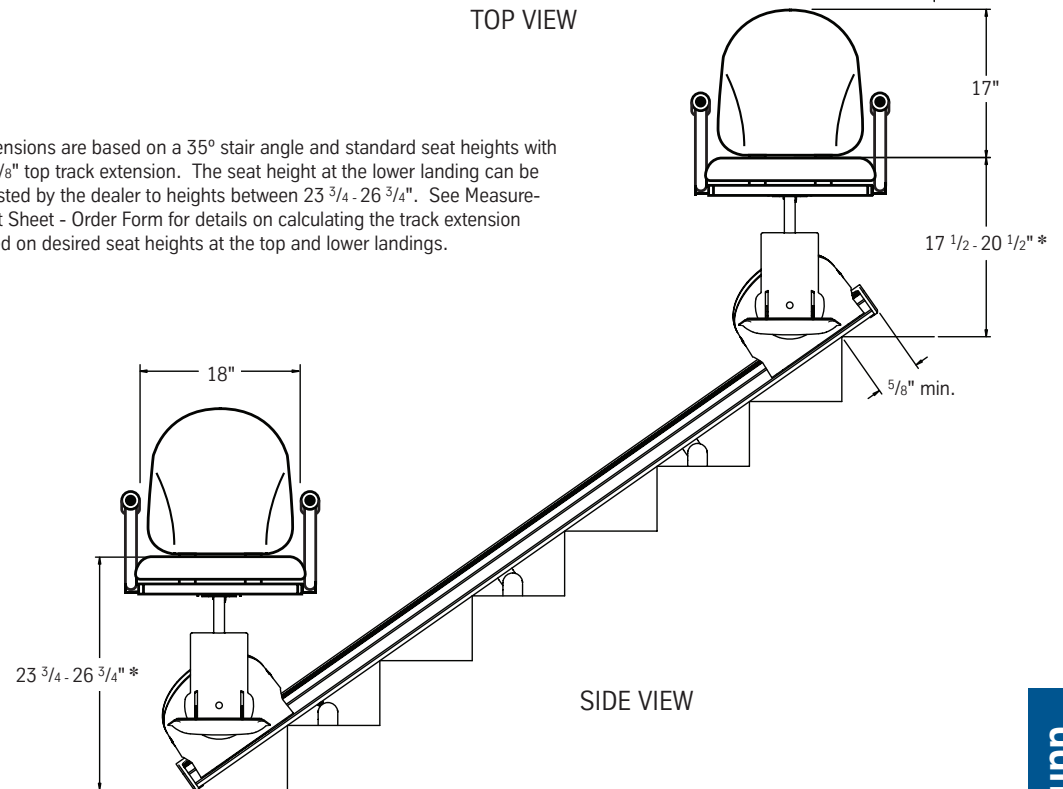

SIDE VIEW

ThyssenKrupp Access
 Accessibility Division



ThyssenKrupp